

2MP, TRUE DAY/NIGHT, WDR, IR VANDAL DOME



Vandal Dome

IPV240

- > Exceptional Video Quality with 2MP, Full HD 1920 x 1080 Resolution
- > Super-Efficient H.265 Video Compression for Drastically Reduced Bandwidth and Storage Requirements
- > Powerful, Smart IR LED Lights for 0Lux Night Time Operation up to 98 Feet
- > 4.0mm fixed lens
- > TRUE Day/Night and Digital WDR functionality for all Lighting Conditions
- > Backlight Compensation and 3D DNR (Digital Noise Reduction)
- > Triple Video Streams
- > ONVIF Profile S Compliant
- > PoE & 12VDC Power Options
- > IP66 Weather Resistant and IK10 Vandal Resistant Rated Vandal Housing
- > Optional Wall and Pendant Mounts Available
- > Supported by uniview tec Video Management Software and Mobile App's for iPhone and Android Devices

Specifications

Camera	
Sensor	1/2.7", progressive scan , 2 megapixel, CMOS
Lens	4.0 mm@ F2.2
Angle of View (H)	76.6°
Shutter	Auto/Manual, 1/6~1/100000 s
Minimum Illumination	Color: 0.2 Lux (F2.2, AGC ON); 0 Lux with IR
Day/Night	IR-cut filter with auto switch (ICR)
Digital noise reduction	2D/3D DNR
IR LED Range	Up to 30m (98 ft) IR range
WDR	Digital
Video Compression	Ultra 265, H.265, H.264, MJPEG
H.264 code profile	Baseline profile, Main Profile, High Profile
Frame Rate	Main Stream: 2MP (1920×1080) Sub Stream: 720P (1280×720) Third Stream: D1 (720×576): Max. 25fps
HLC, BLC, ROI, Defog	Supported
Privacy Mask & Motion Detection	Up to 4 areas
Network	
Protocols	IPv4, IGMP, ICMP, ARP, TCP, UDP, DHCP, RTP, RTSP, RTCP, DNS, DDNS, NTP, FTP, UPnP, HTTP, HTTPS, SMTP
Compatible Integration	ONVIF (Profile S, Profile G), API
Network	RJ45, 10/100 Base-T Ethernet
General	
Power	12 V DC, PoE (IEEE802.3 af) Power consumption: Max 5.0W
Dimensions (Ø x H)	Ø109 x 81 mm (Ø4.3" x 3.2")
Weight	0.3 kg (0.66 lb)
Operating Temperature & Humidity	-30°C ~ +60°C (-22°F ~ 140°F); Humidity:10%~95% RH (non-condensing)
Ingress & Impact Protection	IP66, IK10
Conformity Certifications	CE, FCC

Dimensions

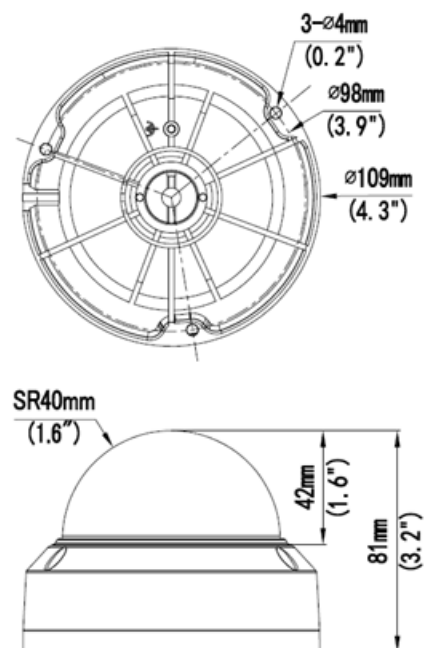

Accessories

TR-WM03-C-IN	Wall Mount
TR-UP06-IN	Pole Mount
TR-JB03-D-IN	Junction Box
TR-UM06-B-IN	Wedge Mount
TR-CE45-IN	Pendant Mount
TR-UF45-D-IN	Pendant Mount Adapter