

## POLE MOUNT



### TR-UP08-A-IN

Specification	Description
Application	Pole installation of PTZ dome camera; 2.6" ~ 5" diameter poles
Dimensions (LxWxH)	215 x 170 x 51.4mm (4.7 x 6.7 x 2")
Weight	1.47kg (3.2lb)
Material	Aluminum Alloy

#### Dimensions

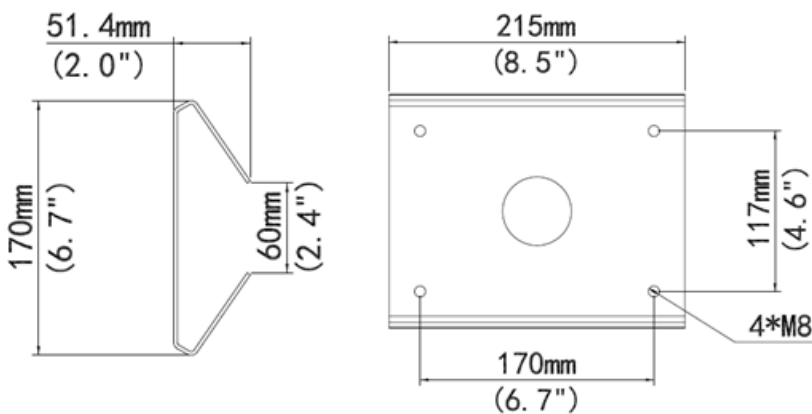

#### Note

1. Requires TR-WE45-A-IN Wall Mount