

2MP, TRUE DAY/NIGHT, D-WDR, IR VANDAL DOME



Fixed Lens Vandal Dome

IPV240

- > Brilliant Video Quality with 2MP, Full HD 1920 x 1080 Resolution
- > Super-Efficient H.265 Video Compression for Drastically Reduced Bandwidth and Storage Requirements
- > Powerful, Smart IR LED Lights for 0Lux Night Time Operation up to 98 Feet
- > 4.0mm fixed lens
- > TRUE Day/Night and Digital WDR functionality for all Lighting Conditions
- > Backlight Compensation and 3D DNR (Digital Noise Reduction)
- > Triple Video Streams
- > ONVIF Profile Series Compliant
- > PoE & 12VDC Power Options
- > IP66 Weather Resistant and IK10 Vandal Resistant Rated Vandal Housing
- > Optional Mounts Available
- > Supported by uniview tec Guard Station Software and Guard Viewer Mobile App's for iPhone and Android Devices

Specifications

Camera	
Sensor	1/2.7", progressive scan, 2 megapixel, CMOS
Lens	4.0 mm @ F2.2
Angle of View (H x V)	86.5° x 44.1°
Shutter	Auto/Manual, 1 ~ 1/100000 s
Minimum Illumination	Color: 0.02 Lux (F2.0, AGC ON); 0 Lux with IR
Day/Night	IR-cut filter with auto switch (ICR)
Digital noise reduction	2D/3D DNR
IR LED Range	Up to 30m (98 ft) IR range
Signal /Noise Ratio	>52dB
WDR	Digital
Video Compression	Ultra 265, H.265, H.264, MJPEG
H.264 code profile	Baseline profile, Main Profile, High Profile
Maximum Frame Rate / Stream	Main: 2MP (1920 x 1080) @ 30fps Sub: 720P (1280 x 720) @ 30fps Third: D1 (720 x 576) @ 30fps
HLC, BLC, ROI	Supported
Privacy Mask & Motion Detection	Up to 8 areas
Network	
Protocols	IPv4, IGMP, ICMP, ARP, TCP, UDP, DHCP, RTP, RTSP, RTCP, DNS, DDNS, NTP, FTP, UPnP, HTTP, HTTPS, SMTP, SSL
Compatible Integration	ONVIF (Profile S, Profile T), API
Network	RJ45, 10M/100M Base-TX Ethernet
General	
Power	12VDC +/- 25%, PoE (IEEE802.3 af) Power consumption: Max 4.5W
Dimensions (Ø x H)	Ø109 x 81 mm (Ø4.3" x 3.2")
Weight	0.37 kg (0.81lb)
Operating Temperature & Humidity	-30°C ~ +60°C (-22°F ~ 140°F); Humidity: 10%~95% RH (non-condensing)
Conformity Certifications	IP66, IK10, CE, FCC

Dimensions

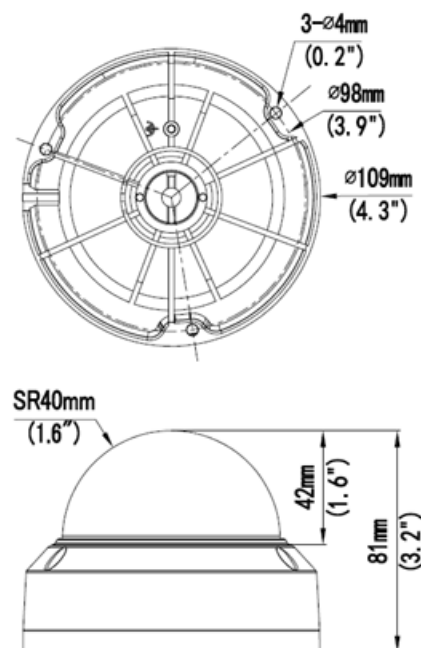

Accessories

TR-WM03-C-IN	Wall Mount
TR-UP06-IN	Pole Mount
TR-JB03-G-IN	Junction Box
TR-UM06-B-IN	Wedge Mount
TR-CE45-IN	Pendant Mount
TR-UF45-D-IN	Pendant Mount Adapter